



常规系列 (General purpose) DJM6190(6V190Ah)



规格 Specifications

额定电压 Rated Voltage	6V	
标称容量 Nominal Capacity(C ₁₀ , 1.80V/cell)	180.0Ah	
尺寸 Dimension	长 Length	306±2mm (12.0 in.)
	宽 Width	168±2mm (6.61 in.)
	高 Container Height	222±3mm (8.74 in.)
	总高(含端子) Total Height	228±3mm (8.98 in.)
重量 Approx Weight	28.0 Kg (61.7 lbs)	
端子 Terminal	M8	
外壳材料 Container Material	ABS	
额定容量 Rated Capacity (25°C)	194.2Ah	(20hr, 9.71A, 1.80V/cell)
	190.0Ah	(10hr, 19.0A, 1.80V/cell)
	168.5Ah	(5hr, 33.7A, 1.75V/cell)
	153.3Ah	(3hr, 51.1A, 1.75V/cell)
	116.3Ah	(1hr, 116.3A, 1.67V/cell)
5S最大放电电流 Max. Discharge Current	1900.0A (5s)	
内阻 Internal Resistance (25°C)	Approx 1.5mΩ	
运行温度 Operating Temp. Range	放电 Discharge	-20 ~ 55°C (-4 ~ 131°F)
	充电 Charge	0 ~ 40°C (32 ~ 104°F)
	存储 Storage	-15 ~ 50°C (5 ~ 122°F)
推荐温度 Nominal Operating Temp. Range	25±5°C (77±5°F)	
最大充电电流 (25°C) Max. Charging Current	57.0A	
充电电压 (25°C) Charge voltage	浮充 Float	6.75V
	温度补偿 Temp. Coefficient	-3mV/单格/°C
	循环(均充) Cycle(Equalization)	7.05~7.20V
温度对容量影响 Effect of temp. to Capacity	40°C (104°F)	106%
	25°C (77°F)	100%
	0°C (32°F)	86%
自放电 Self Discharge	≤3%/月 @ 25°C	



外形 Layout

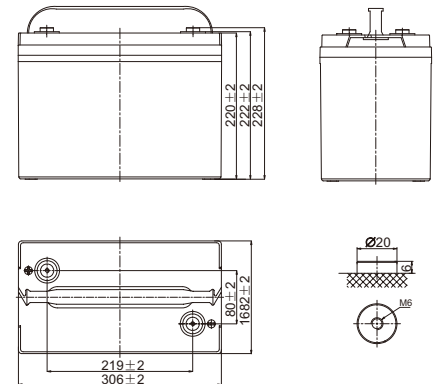

恒流放电表(A) 25 °C Constant Current Discharge

F.V/Time	5min	10min	15min	20min	30min	45min	1h	1.5h	2h	3h	4h	5h	6h	8h	10h	20h
1.85V/cell	377.2	268.2	237.3	186.6	166.8	122.0	103.3	74.9	63.0	46.2	36.2	31.5	27.7	21.3	17.7	9.37
1.80V/cell	429.0	304.4	268.9	211.0	181.7	129.3	107.1	77.5	65.0	50.1	38.7	33.1	29.8	22.4	19.0	9.71
1.75V/cell	466.0	330.2	291.1	227.8	185.4	133.9	112.3	81.4	68.5	51.1	39.4	33.7	30.0	22.5	19.1	9.81
1.70V/cell	498.1	352.0	309.2	241.5	189.1	136.6	114.6	83.0	69.8	52.1	40.1	34.2	30.2	22.9	19.2	9.91
1.67V/cell	515.5	363.2	318.2	248.1	191.9	138.6	116.3	84.3	70.8	52.6	40.7	34.9	30.3	23.2	19.2	10.0
1.60V/cell	533.8	375.6	328.1	254.5	194.6	140.6	117.9	85.5	71.9	53.1	41.2	35.4	30.5	23.5	19.3	10.1

恒功率放电表(W) 25 °C Constant Power Discharge

F.V/Time	5min	10min	15min	20min	30min	45min	1h	1.5h	2h	3h	4h	5h	6h	8h	10h	20h
1.85V/cell	690.1	494.3	437.2	345.3	310.2	234.6	194.5	141.4	119.2	87.8	69.2	60.3	54.8	41.2	34.2	18.2
1.80V/cell	772.0	552.9	489.0	386.3	335.1	246.9	200.4	145.4	122.5	94.9	73.6	63.1	58.6	43.2	35.7	18.8
1.75V/cell	823.9	590.1	521.9	412.3	339.3	254.3	209.3	152.2	128.4	96.5	74.7	64.0	58.9	43.3	36.1	19.0
1.70V/cell	866.2	620.4	548.7	433.4	343.2	257.6	212.4	154.5	130.4	98.0	75.7	64.9	59.1	43.9	36.4	19.1
1.67V/cell	880.2	630.5	557.6	440.5	345.6	259.9	214.3	156.0	131.8	98.5	76.6	66.0	59.2	44.4	36.8	19.3
1.60V/cell	892.6	639.3	565.4	446.7	347.1	261.2	215.9	157.2	132.9	98.9	77.2	66.6	59.4	44.9	37.2	19.5



常规系列 (General purpose) DJM6190(6V190Ah)



应用 Applications

- 通讯
Telecommunications
- UPS、数据中心
UPS、Data Center
- 储能、电力
Energy Storage、Electric Systems
- 紧急照明、安防
Emergency Lighting、Security
- 医疗、电子设备
Medical、Electronic Equipment
- 动力
Motive Power

特征 General Features

- 25°C下，设计浮充寿命可达12年。
Under 25°C, the designed floating life is up to 12 years.
- 特殊的排气结构和密封技术, 使用安全可靠, 安装灵活, 维护便捷。
Special exhaust structure and sealing technology, safe and reliable, flexible installation, convenient maintenance.

标准 Standards

- 符合IEC 60896, GB/T19638, YD/T 799和DL/T 637标准
Compliance with IEC 60896, GB/T19638, YD/T 799 and DL/T 637 standards
- UL 认证, 泰尔认证
UL Certified, TLC Certified
- 企业通过了IATF16949, OHSAS 18001, ISO 9001和ISO 14001体系认证
Manufactured in Leoch@IATF16949, OHSAS 18001, ISO 9001 and ISO 14001 certified production facilities

放电特性曲线 Discharge Characteristics

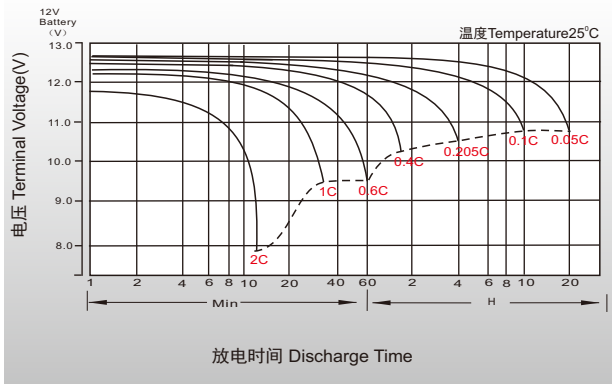

浮充特性曲线 Float Charging Characteristics

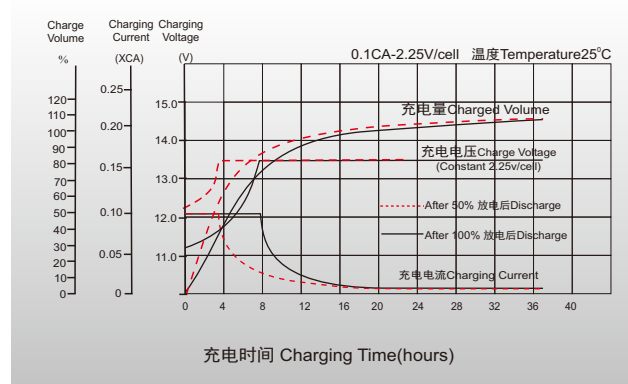

温度对容量影响 Temperature Effects in Relation to Battery Capacity

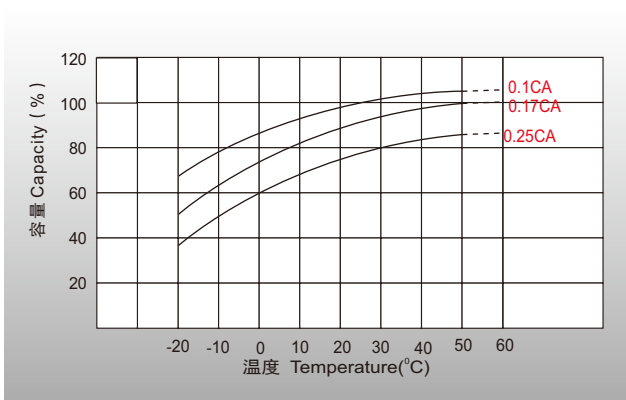

温度对浮充寿命影响 Temperature Effects on Long Term Float Life

