

SN12050 12V 50AH

铅酸蓄电池参数表

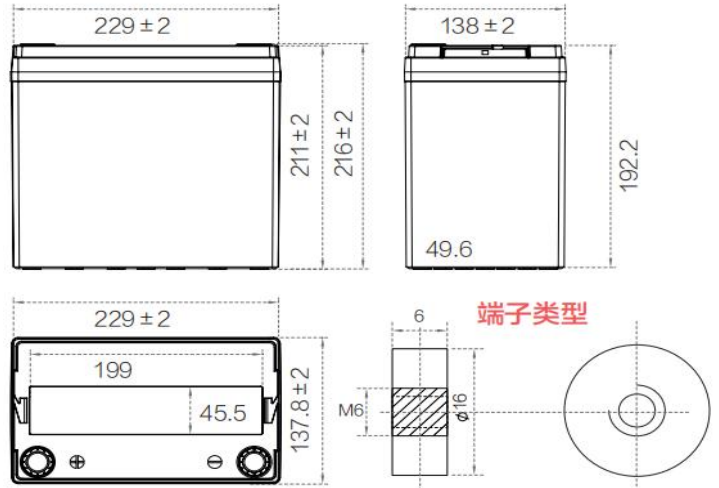

电池外形尺寸 (±2mm)



电池标准

标称电压	12V	
标称容量 (20hr)	50AH	
外形尺寸	长	229±2mm(9.02inch)
	宽	138±2mm(5.43inch)
	高	211±2mm(8.30inch)
	总高	216±2mm(8.50inch)
重量	Approx.15.3±3%kg(±3%)	
端子	M6嵌入式铜芯端子	
内阻	Approx.10±15% $m\Omega$	
最大放电电流	500A(5S)	
浮充期待寿命	8~10年 (20~25℃)	

电池特性

容量(25℃)	48.0Ah	(20hr, 1.70V/cell, 25℃/77°F)
	46.0Ah	(10hr, 1.75V/cell, 25℃/77°F)
	36.0Ah	(3hr, 1.70V/cell, 25℃/77°F)
	26.4Ah	(1hr, 1.60V/cell, 25℃/77°F)
环境温度对容量的影响	40℃	103%
	25℃	100%
	0℃	86%
	-15℃	65%
自放电	3个月	Remaining capacity: 91%
	6个月	Remaining capacity: 82%
	12个月	Remaining capacity: 65%

恒功率参数 (25℃(77°F))

F.V/Time	5min	10min	15min	20min	30min	45min	1h	2h	3h	4h	5h	6h	8h	10h	20h
1.85V/cell	162.9	138.4	116.8	101.3	85.7	62.2	58.3	32.7	23.2	19.1	15.0	13.0	10.9	7.66	4.69
1.80V/cell	177.7	148.1	122.7	111.8	88.6	64.5	60.1	33.2	24.2	19.5	15.6	13.8	11.4	8.55	4.73
1.75V/cell	200.9	166.0	131.5	114.8	91.7	65.6	61.3	34.9	24.7	19.7	16.0	13.9	11.5	8.64	4.75
1.70V/cell	224.3	179.2	141.3	120.9	93.7	66.6	62.6	36.0	25.1	20.0	16.2	14.0	11.6	8.69	4.76
1.65V/cell	239.3	183.9	144.3	123.0	94.9	67.2	63.9	37.1	25.4	20.1	16.3	14.1	11.7	8.73	4.78
1.60V/cell	243.6	186.1	145.7	123.6	95.9	68.9	64.8	37.2	25.8	20.3	16.8	14.3	11.7	8.78	4.78

恒流参数 (25℃(77°F))

F.V/Time	5min	10min	15min	20min	30min	45min	1h	2h	3h	4h	5h	6h	8h	10h	20h
1.85V/cell	121.1	105.2	77.4	63.2	49.3	28.0	23.7	14.9	12.2	9.5	7.81	6.71	5.00	4.48	2.35
1.80V/cell	122.3	107.9	79.0	63.3	49.7	32.6	26.4	15.3	12.3	9.7	7.88	6.74	5.31	4.49	2.39
1.75V/cell	124.0	109.1	79.8	64.5	50.1	33.8	27.7	15.7	12.4	9.9	7.96	6.76	5.39	4.50	2.40
1.70V/cell	132.9	111.4	81.3	65.7	50.8	35.1	28.5	16.1	12.6	10.1	8.03	6.82	5.47	4.50	2.41
1.65V/cell	141.8	113.0	85.2	69.6	51.5	36.0	29.1	16.4	12.8	10.1	8.10	6.93	5.58	4.51	2.41
1.60V/cell	150.7	120.8	89.2	74.3	52.8	37.5	29.5	16.8	13.2	10.5	8.18	6.98	5.62	4.52	2.41

以上参数仅供参考, 偏差范围±5%。

SN12050 12V 50AH

铅酸蓄电池参数表

放电特性

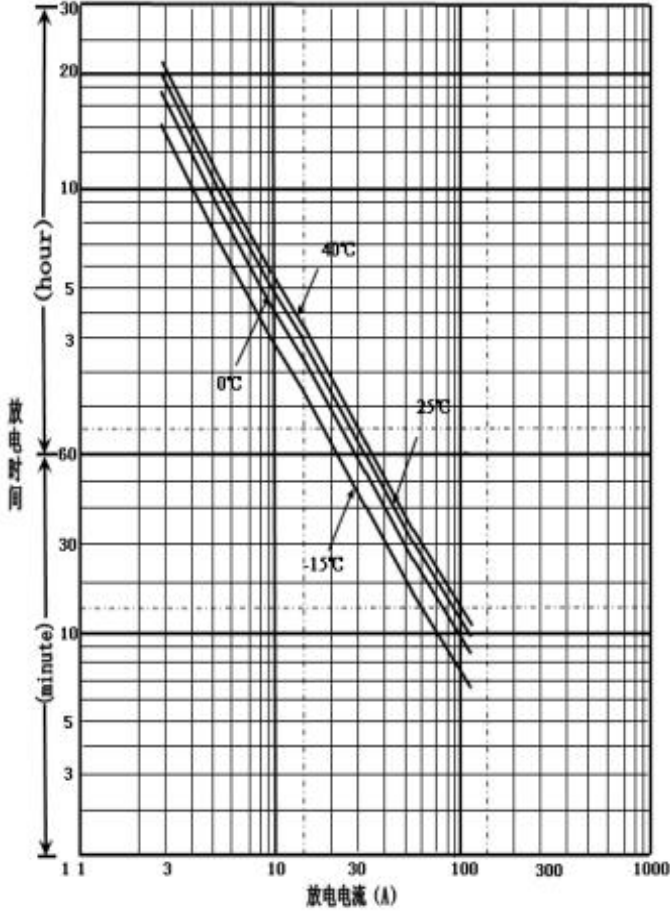

充电特性

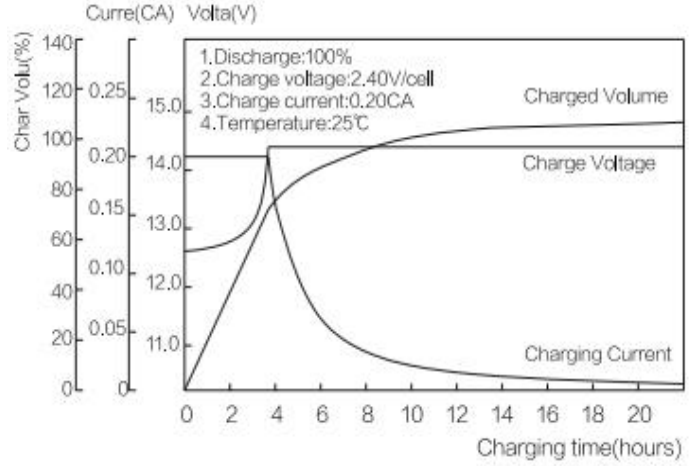

自放电特性 (25°C (77°F))

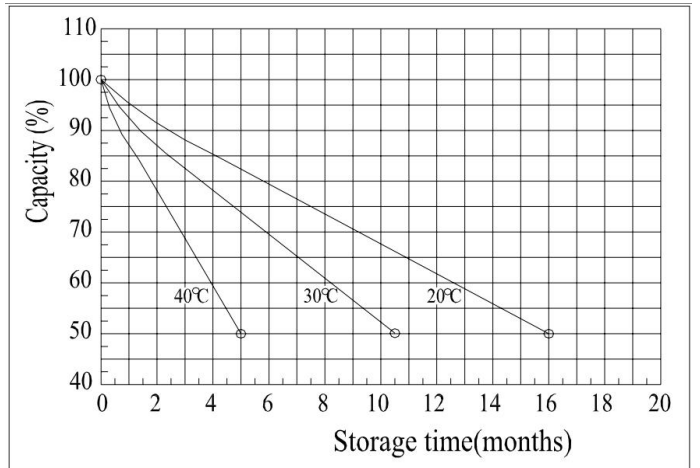

温度对容量的影响

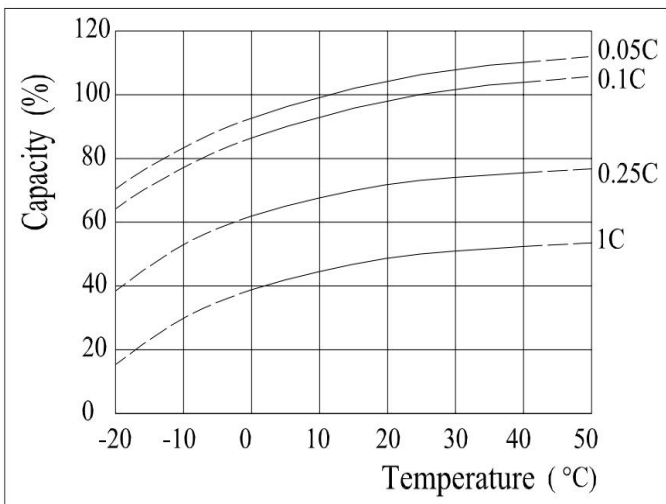

深度放电与循环寿命

