

# SN12200 12V200AH

## 铅酸蓄电池参数表

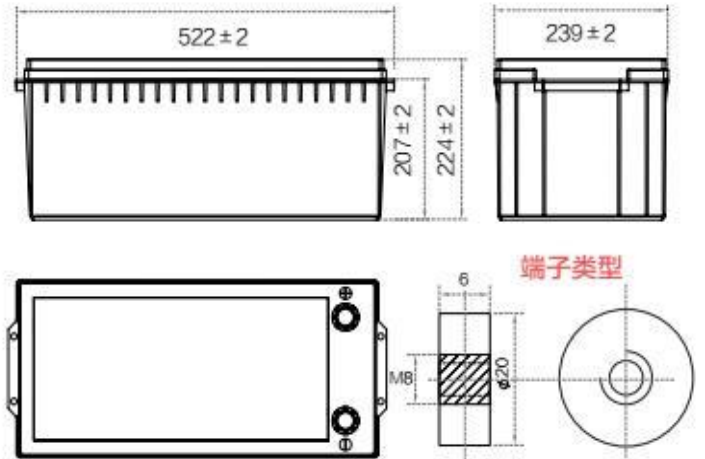

### 电池外形尺寸 (±2mm)



### 电池标准

标称电压	12V		
标称容量 (20hr)	200Ah		
外形尺寸	长	522±2mm(20.55inch)	
	宽	239±2mm(9.40inch)	
	高	217±2mm(8.54inch)	
	总高	224±2mm(8.81inch)	
重量	Approx.54.5±3%kg		
端子	M8嵌入式铜芯端子		
内阻	Approx.4±15% $\Omega$		
最大放电电流	2000A(5S)		
浮充期待寿命	8~10年 (20~25℃)		

### 电池特性

容量(25℃)	200.0Ah	(20hr, 1.70V/cell,25℃/77°F)
	180.0Ah	(10hr, 1.75V/cell,25℃/77°F)
	160.0Ah	(3hr, 1.70V/cell,25℃/77°F)
	115.0Ah	(1hr, 1.60V/cell,25℃/77°F)
环境温度对容量的影响	40℃	103%
	25℃	100%
	0℃	86%
	-15℃	65%
自放电	3个月	Remaining capacity: 91%
	6个月	Remaining capacity:82%
	12个月	Remaining capacity:65%

### 恒功率参数 (25℃(77°F))

F.V/Time	5min	10min	15min	20min	30min	45min	1h	2h	3h	4h	5h	6h	8h	10h	20h
1.85V/cell	717	543	506	483	378	262	203	135	92	74.2	64.7	54.5	44.4	36.3	19.6
1.80V/cell	762	640	632	522	390	274	209	139	97	78.5	67.5	57.9	46.5	36.9	19.8
1.75V/cell	844	724	655	534	401	284	226	142	99	80.3	68.7	59.0	47.3	37.2	19.8
1.70V/cell	929	771	689	561	407	289	238	145	100	81.4	69.6	59.9	47.7	37.6	19.8
1.65V/cell	/	825	694	567	419	295	243	146	102	83.4	69.9	60.6	47.9	38.0	19.8
1.60V/cell	/	844	698	570	432	306	245	150	103	85.5	70.1	61.1	48.1	38.6	19.8

### 恒流参数 (25℃(77°F))

F.V/Time	5min	10min	15min	20min	30min	45min	1h	2h	3h	4h	5h	6h	8h	10h	20h
1.85V/cell	451	416	317	265	196	142	114	76.5	53.4	41.7	34.1	28.0	24.5	18.0	9.63
1.80V/cell	495	417	329	277	205	148	116	78.5	53.8	43.4	35.3	28.2	26.0	18.0	9.66
1.75V/cell	542	422	338	287	213	153	118	80.4	54.3	44.1	36.8	28.4	26.4	18.0	9.64
1.70V/cell	563	429	349	294	217	159	122	82.3	55.1	45.2	37.6	28.9	26.8	18.0	9.64
1.65V/cell	628	455	355	298	222	160	127	84.3	55.4	45.7	38.3	29.1	27.4	18.0	9.73
1.60V/cell	634	460	359	301	225	162	132	86.2	56.0	46.4	39.1	30.3	28.3	18.0	9.73

以上参数仅供参考，偏差范围±5%。

# SN12200 12V200AH

## 铅酸蓄电池参数表



### 放电特性

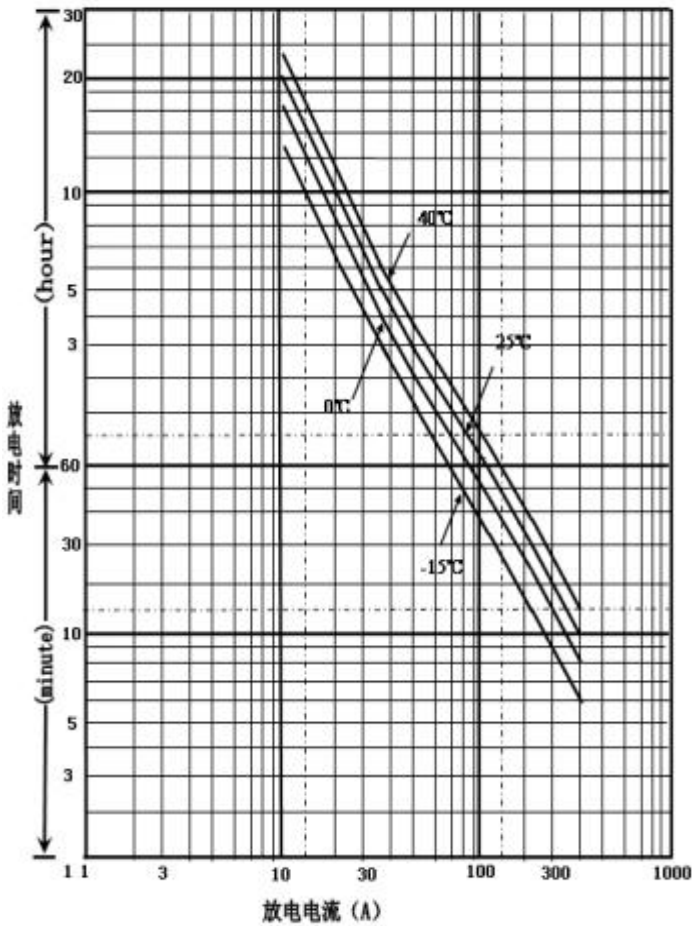

### 充电特性

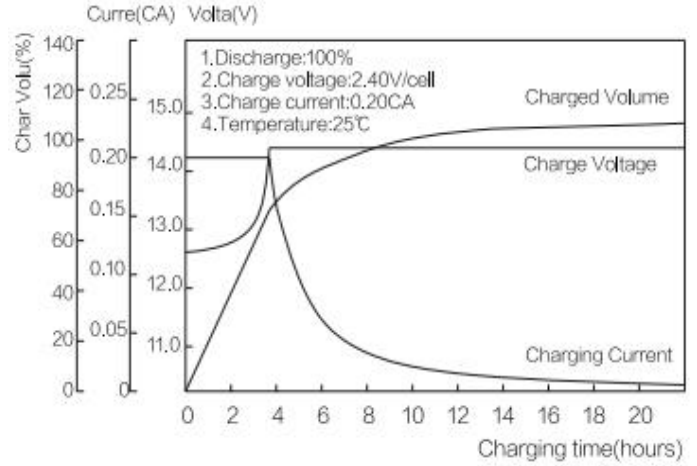

### 自放电特性 (25°C (77°F))

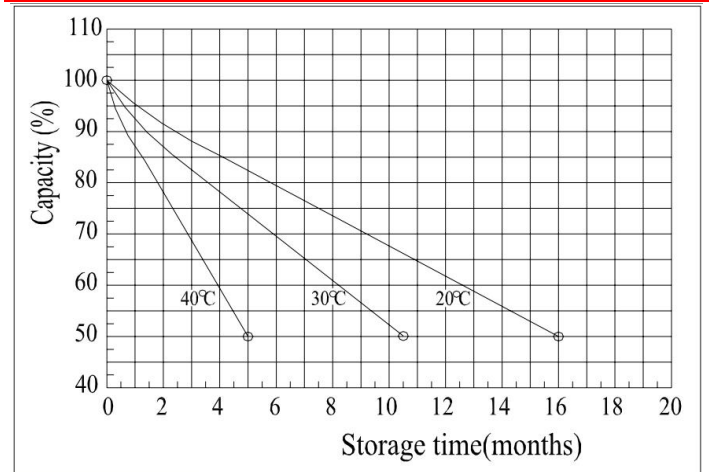

### 温度对容量的影响

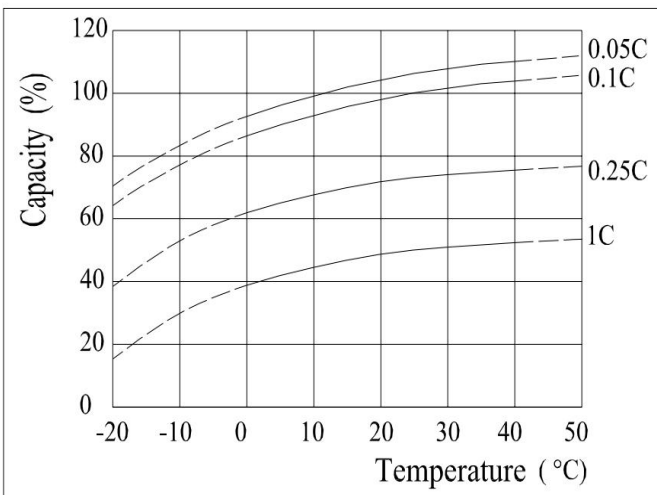

### 深度放电与循环寿命

