

Powered by



# UXL12V120AH ▶ 12V120Ah

UXL系列采用阀控密封氧复合技术,特殊的耐腐蚀合金,高强度AGM隔板,高纯度材料使电池自放电小,寿命长.

UXL series uses valve control sealed oxygen composite technology, special corrosion resistant alloy, high strength AGM separator, high purity material to make the battery self-discharge is small, long service life.



目录Table of contents

额定电压 Rated Voltage	12
额定容量Nominal Capacity(C10@1.8V@25°C)	120Ah
重量Approx Weight	34.5kg ±3%(76.06lbs)
最大放电电流Max. Discharge Current	1200A(5S)
内阻Internal Resistance(25°C)	4.5mΩ
工作温度范围Operating Temp. Range	放电Discharge: -15°C~50°C(5°F~122°F) 充电Charge: -15°C~40°C(5°F~104°F) 储存Storage: -15°C~40°C(5°F~104°F)
推荐工作温度Nominal Operating Temp. Range	25°C±3°C(77°F±5°F)
最大充电电流Max.Charging Current(25°C)	36A
浮充电压Float voltage	13.5~13.8V@25°C(77°F)
均充电压Equalizing voltage	14.1~14.4V@25°C(77°F)
端子Terminal	M8
外壳材质Container Material	ABS(UL 94-V0)(UL 94-HB)



IT1548HL06061801



尺寸Dimension :	长Length	宽Width	高Container Height	总高Total Height
单位unit: mm	331±2.5	175±1.5	215±2.5	221±2.5

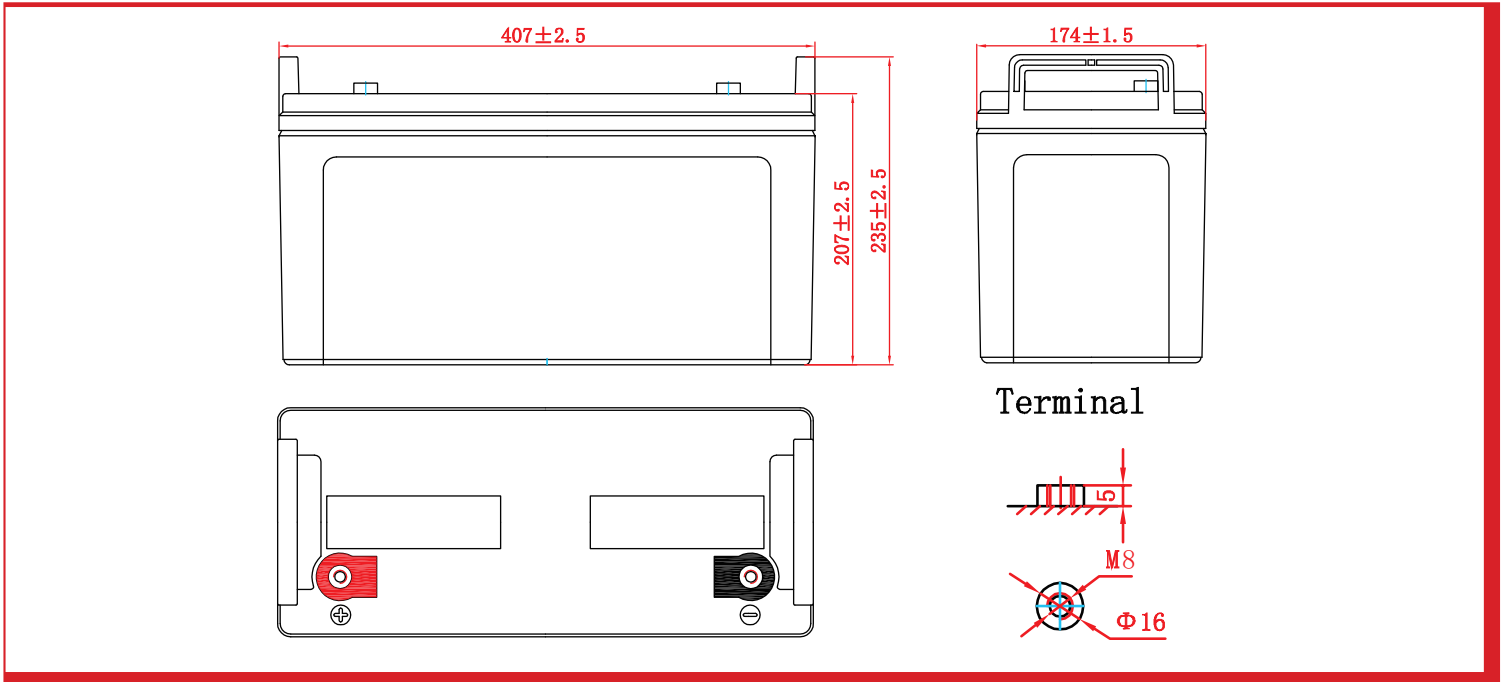

恒流放电表 Constant current discharge meter 单位 Unit: 安培 A(25°C/77°F)

F.V/Time	10min	15min	30min	1h	3h	5h	10h	20h
1.60V	267	201	126	76.3	32.1	21.5	12.3	6.56
1.67V	260	196	124	75.3	31.8	21.4	12.3	6.54
1.70V	255	192	122	74.4	31.6	21.3	12.3	6.52
1.75V	240	182	118	72.0	31.0	20.9	12.2	6.46
1.80V	219	169	112	68.9	29.9	20.4	12.0	6.36
1.85V	189	148	105	63.9	27.4	18.9	11.5	6.15

恒功率放电表 Constant power discharge meter 单位 Unit: 瓦特/单格 W/cell(25°C/77°F)

F.V/Time	10min	15min	30min	1h	3h	5h	10h	20h
1.60V	479	386	239	145	63.2	42.0	24.2	12.9
1.67V	454	366	235	143	62.6	41.9	24.1	12.8
1.70V	435	351	232	142	62.2	41.8	24.1	12.8
1.75V	394	318	224	139	61.0	41.3	23.9	12.7
1.80V	345	281	214	134	58.8	40.1	23.6	12.5
1.85V	282	232	200	127	54.6	37.7	22.8	12.2

温度对浮充寿命的影响

Temperature Effects on Long Term Float Life

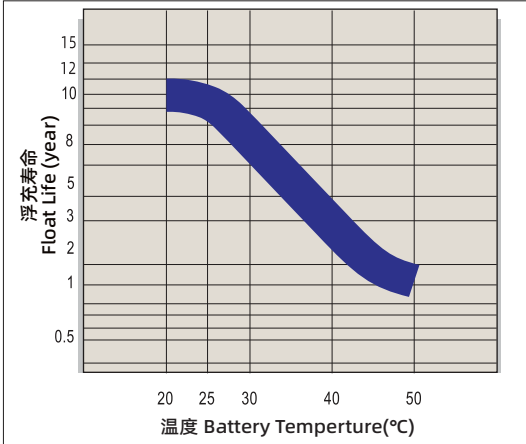

温度对容量的影响

The effect of temperature on capacity

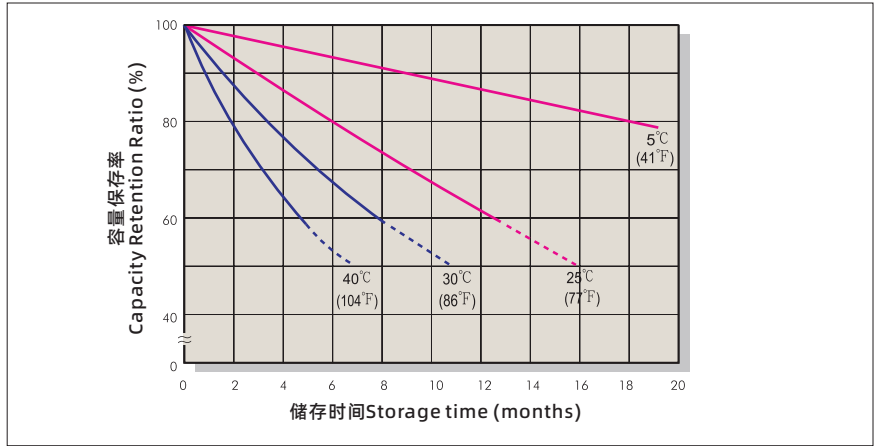

浮充特性曲线

Float Charging Characteristics

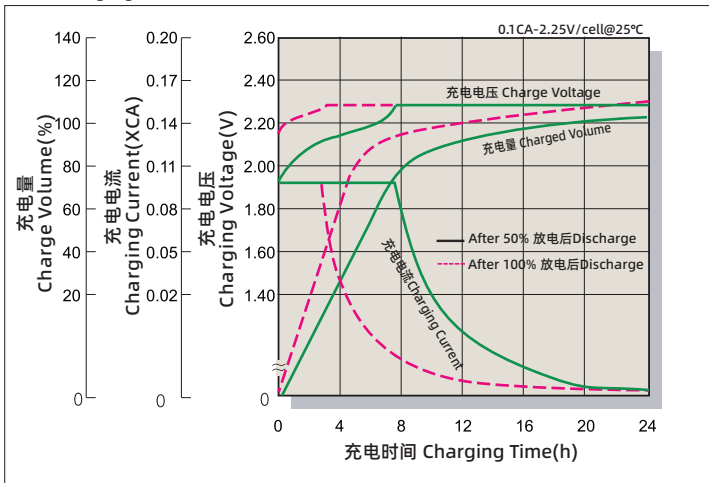

放电特性曲线

Discharge Characteristics

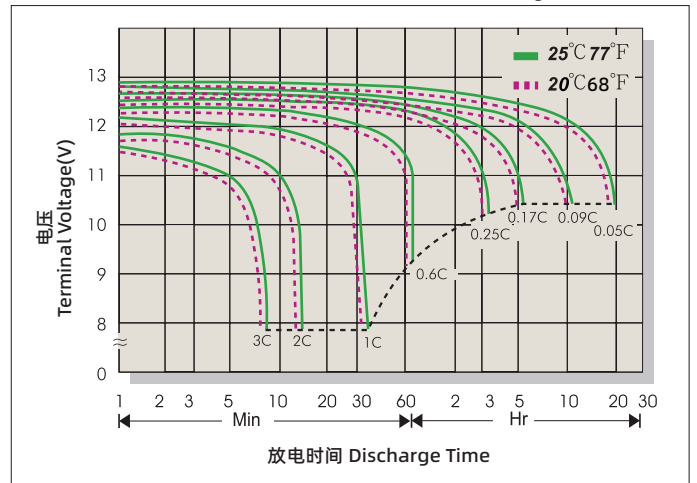

温度对容量的影响

The effect of temperature on capacity(10HR)

温度 Temperature	容量 Capacity(10HR)
40°C	103%
25°C	100%
0°C	85%
-15°C	65%

自放电特性

Self-discharge characteristics

存放时间 Storage time	剩余容量 The remaining capacity
3月 months	91%
6月 months	82%
12月 months	64%

### 应用 Applications

- 通讯 Telecommunications
- UPS、数据机房 UPS、Data Rooms
- 紧急照明、安防 Emergency Lighting、Security
- 储能、电力 Energy Storage、Electric Systems
- 新能源系统 New Energy Systems

Baace生产的电池阀控式铅酸蓄电池通过UL认证 (UL2000)

Baace-manufactured VRLA(Absorbent Glass Mat type)batteries are UL-recognized Components under UL1989.

Baace也通过了认证ISO 9001和ISO 14001。

Baace is also certified by ISO 9001 and ISO 14001.

## 江西恒力电池科技有限公司

JIANGXI HENGLI TECHNOLOGY BATTERY CO.,LTD.

地址:江西省抚州市抚北工业园广银大道